

ARES: ACCELERATOR RESEARCH EXPERIMENT AT SINBAD

B. Marchetti, R. W. Assmann, C. Behrens, R. Brinkmann, U. Dorda, K. Floettmann, J. Grebenyuk, M. Huening, Y. Nie, H. Schlarb, J. Zhu, DESY, Hamburg, Germany

Abstract

ARES is a planned linear accelerator for R&D for production of ultra-short electron bunches. It will be hosted at the SINBAD facility, at DESY in Hamburg [1]. The goal of ARES is to produce low charge (0.2 - 50 pC), ultra-short (from few fs to sub-fs) bunches, with high arrival time stability (less than 10fs) for various applications, such as external injection for Laser Plasma Wake-Field acceleration [2]. The baseline layout of the accelerator foresees an S-band photo-injector which compresses low charge electron bunches via velocity bunching and accelerates them to 100 MeV energy. In the second stage, it is planned to install a third S-band accelerating cavity to reach 200 MeV as well as two X-band cavities: one for the linearization of the longitudinal phase space (subsequently allowing an improved bunch compression) and another one as a Transverse Deflecting Cavity (TDS) for longitudinal beam diagnostics. Moreover a magnetic bunch compressor is envisaged allowing to cut out the central slice of the beam [3] or hybrid bunch compression.

INTRODUCTION

Ultra-short electron bunches, having a RMS length below 1 fs, are of great interest for various applications. First of all they can be used for ultrafast science, for example to generate ultra-short radiation pulses or to run electron diffraction experiments. Moreover they are expected to allow superior performances when injected into novel compact accelerating structures (e.g. based on Plasma Wake-Fields Acceleration). Besides studying novel acceleration techniques aiming to produce high brightness short bunches, the ARD group at DESY is working on the design of a conventional RF accelerator that will be hosted at SINBAD (Short and INnovative Bunches and Accelerators at Desy). ARES (Accelerator Research Experiment at Sinbad) will allow the production of such ultra-short bunches and the direct experimental comparison of the performance achievable by using different compression techniques. At a later stage ARES will be used to inject ultra-short electron bunches into laser driven Plasma Wake-field Accelerator.

Limits for the Bunch Length Compression

The factors limiting the minimum bunch length in the field of linear accelerators are well known. The main limitation is the space charge repulsion among the electrons in the bunch. As the effect scales as γ^{-2} (with γ being the relativistic factor of the beam), it limits the maximum electron densities especially at low energies [4].

The next limitation is set by the sinusoidal shape of the RF fields or the non-linear space charge force causes non-linear distortions of the distribution of the electrons in the longitudinal phase space [5]. Also a magnetic chicane or a

dogleg, when present, contains non-linear dispersion terms that increase the longitudinal emittance of the beam. Additionally, when the magnetic compression is considered, Coherent Synchrotron Radiation (CSR) further spoils the longitudinal emittance of the beam [6].

Finally the uncorrelated energy spread of the beam, which is related to the minimum achievable spot size of the laser at the photo-cathode plays also a minor role in the optimization [7].

At ARES we plan to accelerate electron bunches with very low charge (0.2 - 50 pC)¹ to moderate energy levels (100-200 MeV) and to compress them to fs and sub-fs bunch-duration.

The chosen energy range allows to relax the space charge limitation, that characterizes the low energy accelerators (3-5 MeV), while dealing with a considerably more compact and relatively simple accelerator than the high energy (>1 GeV) user facilities.

LAYOUT OF THE ACCELERATOR

The project is foreseen to be realized in several stages. In this paper we will refer to two main stages of the installations. A baseline layout will allow the production of ultra-short bunches thanks to the velocity bunching compression technique [8]. The upgraded layout will allow to compress the beam also with the slit method [3] and by using an hybrid velocity bunching scheme. The introduction of a linearizing cavity is also foreseen.

Baseline Layout

Table 1: Main Accelerator Parameters

Parameter	Baseline Layout	Upgraded Layout
Main RF Frequency	2998 MHz	2998 MHz
Rep. Rate	10 Hz	10 Hz
N. of bunches	1	1
Final e- energy	100 MeV	200 MeV
Bunch charge	0.2 pC - 50 pC	0.2 pC - 1nC
Arrival time stability	<50 fs	<10 fs

The baseline layout of ARES is represented in Fig. 1 while a summary of the main accelerator parameters is presented in Table 1. The electron bunch will be generated by photo-emission from a Cs₂Te or metallic cathode embedded in a 1.5 cells, 2.998 GHz frequency, RF gun of the REGAE type [9]. An emittance compensating solenoid having about 0.3 T peak field is placed at the gun exit. The first accelerating

¹ Some of the experiments planned at a later stage in the SINBAD facility would benefit from the use of high charge electron bunches, therefore we plan to make possible the extraction up to ~ 1nC charge from a Cs₂Te cathode.

cavity is a LINAC II type travelling wave structure [10] and is operated as RF compressor. An other travelling wave cavity of the same kind allows the acceleration of the beam up to 100 MeV. Both cavities are surrounded by solenoids.

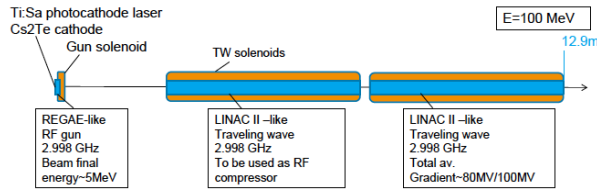

Figure 1: Layout of the ARES accelerator in the first stage of the experiment.

A first study for the bunch compression at low charge (0.5 pC) with the velocity bunching technique has been carried out. Three working points delivering different transverse spot-sizes at the linac exit have been collected in Table 2. In these simulations the entrance of the first travelling wave structure was located at 2.5 m from the cathode. Further details concerning these working points can be found in [11].

Table 2: Beam Parameters – Low Charge Working Points

Parameter	WP1	WP2	WP3
Charge [pC]	0.5	0.5	0.5
FWHM [fs]	2.1	2.7	4
E [MeV]	110	111	111
$\Delta E/E$ [%]	0.1	0.1	0.3
$\sigma_{x,y}$ [mm]	0.6	0.15	0.009
$n\epsilon_{x,y}$ [μm]	0.07	0.05	0.05
I_p (in 1 FWHM) [A]	133	115	87

Upgraded Layout

Figure 2 shows the upgraded layout of the accelerator. A bunch compressor operating with a negative linear momentum compaction (R_{56}) and a dogleg with positive R_{56} will be mounted at the end of the linac. Moreover the introduction of a linearizing cavity is foreseen. In Fig. 2 this cavity is represented at the exit of the gun, according to the scheme proposed in [12]. Nevertheless the discussion concerning the location of the linearizer is still open and we will also consider the possibility of shifting this element after the first travelling wave cavity or at the end of the Sband linac.

In the magnetic compressor scheme, the three travelling wave RF cavities are all operated off crest establishing a linear correlation between the particle energy and its longitudinal coordinate along the bunch. A slit, placed at the centre of the chicane, where the transverse beam dimension is dominated by the particle momentum dispersion, selects a longitudinal slice of the bunch [3].

The beam parameters provided by such a scheme are summarized in Table 3 and more details about this setup can be found in reference [13].

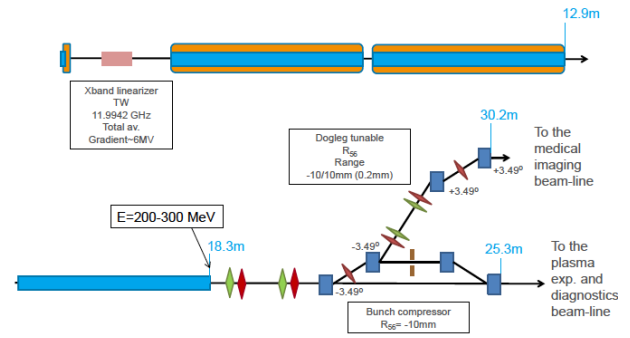

Figure 2: Layout of the ARES accelerator in the second stage of the experiment.

Table 3: Beam Parameters – Low Charge Working Points

Parameter	WPA	WPB
Initial Charge [pC]	10	100
R_{56} [mm]	10	10
Slit width [mm]	0.4	0.4
Final Charge [pC]	0.38	2.77
RMS [fs]	0.2	0.62
$\Delta E/E$ [%]	0.19	0.22
$n\epsilon_{x,y}$ [μm]	0.05	0.05
I_p (in 1 FWHM) [A]	650	1528

The dogleg having positive R_{56} will allow the compensation of the elongation of the beam due to the space charge force after the compression in the linac via velocity bunching. We will refer to this scheme by calling it hybrid compression [11].

A difficult goal to achieve in our project is to fulfill the requirement for arrival time jitter stability given in Table 1. This requirement is set by the application of the ARES beam for an experiment of external injection in a laser driven plasma wake-field accelerator [1]. The upgraded version of the ARES synchronization system is foreseen to provide a local signal RMS jitter below 10 fs. Nevertheless the RF jitter coming from the photo-cathode laser and the RF structures sum up differently according to the working point of the machine. A study of the arrival time jitter for both the pure magnetic compression and velocity bunching setups can be found in [14]. An equivalent study for the hybrid velocity bunching case is also planned.

Longitudinal Diagnostics Section

The measurement of the longitudinal phase space of the electron bunch, particularly the bunch length, is extremely important for our facility.

Longitudinal phase space measurements by means of a Xband RF Transverse Deflecting Structure (TDS) deliver presently the best temporal resolution [15]. For this reason we have started to evaluate the design of a simple beam-line, that is represented in Fig. 3 and 4, for the longitudinal di-

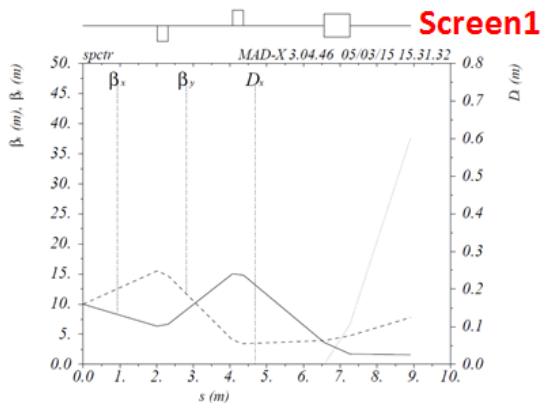

Figure 3: Example of simple beam optics for the longitudinal phase space measurement, delivering 90 degree of phase advance in the vertical plane between the centre of the transverse deflecting cavity and a screen located on a secondary line. The vertical Twiss parameter in the centre of the TDS ($\beta_{y,s0}$), located at $z=0$, is 10 m. The dipole represented in the sketch has an angle of 17.5 degrees with respect to the main line.

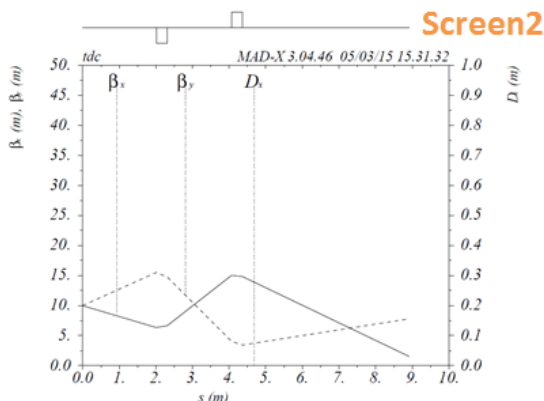

Figure 4: Example of simple beam optics for the bunch length measurement, delivering 90 degree of phase advance in the vertical plane between the centre of the transverse deflecting cavity and a screen located on the straight line.

agnostics of the beam. We assume to locate at the entrance of our diagnostics line a TDS working at 11.992 GHz, deflecting the beam in the vertical direction. The centre of the TDS is located at $z = 0$.

In Figure 5 we have represented the resolution of the bunch length measurement (cfr. references [16, 17]) corresponding to different beam energies and vertical β Twiss parameter in the centre of the TDS. The normalized transverse emittance of the beam was assumed 0.1 mm*mrad.

CONCLUSION

We have presented the status of the design of the layout of the linac located at SINBAD. We have shown the present

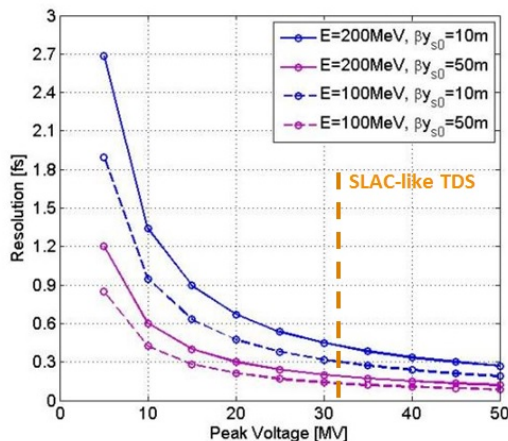

Figure 5: Resolution of the bunch length measurement (cfr. references [16, 17]) for different energies of the electron beam and vertical $\beta_{y,s0}$ Twiss parameter in the centre of the TDS as a function of the deflecting Voltage of the cavity. A phase advance of 90 degrees in the vertical plane between the centre of the TDS and the screen is assumed.

layout foreseen for the facility and the results of the first beam dynamics simulations that have been run.

REFERENCES

- [1] R. Assmann et al., TUPME047, Proceedings of IPAC 2014.
- [2] R. Assmann, J. Grebenyuk, TUOB01, Proceedings of IPAC 2014.
- [3] P. Emma et al., PRL 92 7 (2004).
- [4] M. Reiser, *Theory and design of charged particle beams*, p.368, WILEY-VCH.
- [5] K. Floettmann et al., DESY-TESLA-FEL-2001-06.
- [6] M. Dohlus, WEYFI01, Proceeding of EPAC 2006.
- [7] K. Floettmann, NIM A 740, p. 34-38 (2014).
- [8] M. Ferrario et al., PRL 104, 054801 (2010).
- [9] <http://regae.desy.de/>
- [10] http://min.desy.de/linac_ii_pia/
- [11] B. Marchetti et al., in Proc. of IPAC'15, TUPWA030, these Proceedings.
- [12] L. Serafini and M. Ferrario, AIP Conference Proceedings, Vol 581, pp.87-106 (2001).
- [13] J. Zhu et al., in Proc. of IPAC'15, MOPWA042, these Proceedings.
- [14] J. Zhu et al., in Proc. of IPAC'15, WEPMA031, these Proceedings.
- [15] C. Behrens et al., Nat. Commun. 5, 3762 (2014).
- [16] P. Emma et al., LCLS-TN-00-12 (2000).
- [17] M. Roehrs et al., PRSTAB 12 050704 (2009).